

## Application

The pilot eHEnergizer PHE-120 is specifically designed for igniting gas pilots typically used in process burners found in the refining, oil & gas, petrochemical, and chemical industries.

The igniter is active when 120VAC is supplied. Once power is applied the igniter will provide 800V to the igniter tip. The igniter is designed to work with a Champion High Energy Igniter Tip's available from CSI.

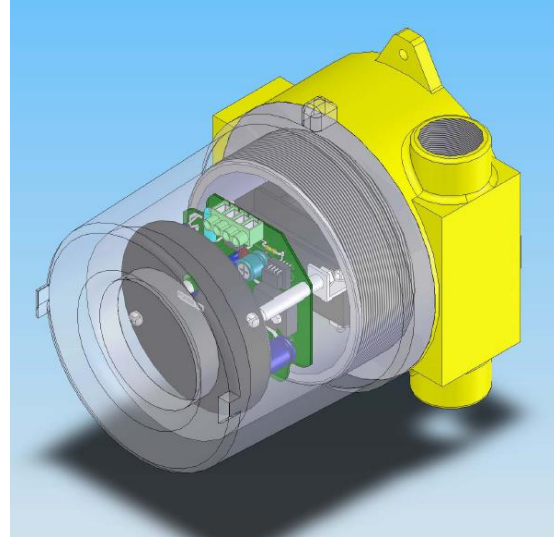

## General Specifications

Physical Dimensions:

6 7/16" X 5 9/32" X 6 1/8"

Supply Voltage:

120VAC

Output Voltage:

800V

Power Consumption:

750 mA maximum

Spark Frequency:

3 per second

Spark energy:

4 Joules per spark

Connections:

3/4" FNPT Igniter Tip Connection

3/4" Electrical Connection

## Environmental Conditions

Temperature Ratings:

Operating: -50°C to 75°C

Enclosure Material

Cast Aluminum

Enclosure Rating:

NEMA 4/IP66

Area Classification:

Class I, Div II, Gr. B, C, & D\*

## Certification

Electronics:

CAN/CSA-C22.2 No.199-89(R2004)

ANSI Z21.20-2005

Killark Enclosure:

UL, CSA, FM

Class 1 Div 2 A,B,C,D

ATEX EEx d



\*Sealing fitting is required on electrical connection for hazardous areas

5468 54 Ave S.E. Calgary, AB T2C 3A5 Canada TEL (403) 547-9722 FAX (403) 547-9760 [www.combustionsolutions.ca](http://www.combustionsolutions.ca)